



DU PONT®

Design > **FYI**

Issue 1 - Hytrel® in Action



## Design > FYI Series

### Welcome to DuPont Design FYI

DuPont Performance Materials (DPM) is pleased to introduce a new product information series for designers that we call Design FYI.

Design FYI has been developed specifically with product designers and engineers in mind, recognizing the creative contribution you make throughout the product development process.

The information presented offers an overview of DPM polymer types, capabilities and processing characteristics. In addition, we include detailed design tips and selected reviews of our materials in action.

This first edition in the series features Hytrel® TPC-ET, the polyester elastomer that provides the flexibility of rubber, the strength of plastic and the processability of thermoplastic.

We believe sharing information on the use of a DuPont material or design idea in one application can suggest its applicability in completely new areas. With this in mind we hope to assist with inspiring your next project and welcome the opportunity to collaborate on future design activities together.

If you would like to continue to receive additional Design FYI information packages, please complete and return the mail-back form included with this publication.

Thanks for your interest in DuPont Performance Materials, we look forward to your comments and suggestions.

## Contents

---

<b>Hytrel® Description</b> .....	<b>4-5</b>
What is Hytrel®? .....	4
Engineered for Versatile Performance .....	4
Hytrel® – A Unique Blend of Capabilities .....	5

---

<b>Hytrel® in Action</b> .....	<b>6-11</b>
Walking on Hytrel® .....	6-7
Niagara Foot .....	6
Fimbulvetr Snowshoe .....	7
Hytrel® in Furniture .....	8-9
Chair Backs .....	8
Bed Springs .....	9
Wearable Hytrel® .....	10-11
Wrist Bands .....	10
Virtual Reality Headsets .....	11
Smart Clothing .....	11

---

<b>DuPont Design Tips</b> .....	<b>12-15</b>
Snap Fits .....	12-13
Seals .....	14-15

---

<b>Hytrel® Applications</b> .....	<b>16-17</b>
Airbag Systems	Medical Device Materials
Cable Insulation and Jacketing	Railway Technology
Blow Molded Air Ducts	Sporting Goods
Food Contact Materials	Tubing and Hoses
Gears	

---

<b>Contact Us</b> .....	<b>20</b>
-------------------------	-----------

DuPont Performance Materials – Regional Locations

Join us on:



# Hytrel®

## What is Hytrel®?

DuPont™ Hytrel® is a TPC-ET thermoplastic polyester elastomer. As a versatile copolyester, it combines resilience and chemical resistance with strength and durability across a wide temperature range.

“ Hytrel® provides the flexibility of rubber, the strength of engineering plastic and processability of thermoplastic. Hytrel® is available in a full range of Shore D hardnesses. ”

## Engineered for Versatile Performance

Hytrel® gives you the power to innovate. It facilitates the design and economical manufacture of a variety of products by combining many of the best features of both high-performance elastomers and flexible plastic materials.

Parts made with Hytrel® resin can flex in multiple directions, cycle after cycle, long after rubber would break. Examples of this behaviour are seen in applications ranging from automotive steering joints (page 5) to rugged snow shoes (page 7).

With Hytrel® it is possible to design unique parts combining multiple functions, such as integrated sealing and spring features. It can also be processed using many thermoplastic methods, in both thick and thin sections, making it an exciting prospect for innovative design engineers.

## Hytrel® – A Unique Blend of Capabilities

### Product Chemistry

**Block Copolymer** – Hytrel® is a block copolymer, consisting of a hard (crystalline) segment of polybutylene terephthalate and a soft (amorphous) segment based on polyether chemistry.

**Properties are determined by the ratio of hard to soft segments and by the composition of the segments.**

**No Plasticizer** – Hytrel® grades are inherently flexible and do not contain plasticizer.

**Hardness Range** – The Hytrel® product line contains grades ranging from Shore D hardnesses of 30 to 82.

### Properties and Characteristics

#### Toughness and Resilience

Hytrel® flexes and recovers, provides excellent fatigue and tear resistance, low hysteresis and spring-like properties, coupled with exceptional impact resistance and creep resistance.

#### Wide Temperature Range

Flexibility at low temperatures and good retention of mechanical properties at high temperatures.

#### Resistance to Chemicals

Stands up to oils, fuels, hydrocarbon solvents, alcohols and many other chemicals.

#### Economical Processing

Hytrel® can be molded by injection, blow or rotational molding techniques; it can be extruded into tubes, profiles, fibers/filaments, sheet, blown or cast film, web coating, nonwovens and wire and cable jacketing. The design and manufacturing flexibility of Hytrel® often results in lighter weight and lower cost parts versus rubbers and other elastomers.

## HYTREL® ADDED TO THE PLASTICS HALL OF FAME

In 2014, the constant velocity joint (CVJ) half-shaft drive-axle boot seal using DuPont™ Hytrel® TPC/ET thermoplastic polyester elastomer was selected as the 2014 Hall of Fame winner. The Hall of Fame award is given to one component in continuous production for at least 15 years that has made a significant and lasting contribution to the application of plastics in automobiles.

General Motors in 1984 was the first to use that year's recipient – CVJ boots made of Hytrel®. The inherent wear resistance and flexibility of Hytrel® significantly improved the durability of CVJ boots, which protect a vehicle's rotating shaft from road debris and axle grease. Today, 85 percent of front-axle CVJ boot seals on light-duty vehicles worldwide use thermoplastic polyester elastomer in this application.

The development of the inaugural program was made by a co-operative team from GM, Nexteer Automotive, formerly GM Saginaw Steering Gear Division, ABC Group and DuPont.

The SPE® Automotive Innovation Awards program is the oldest and largest competition of its kind in the automotive and plastics industries.



## Walking on Hytrel®

The elasticity, resilience and toughness of DuPont Performance Materials' Hytrel® TPC-ET make it particularly relevant to applications that need to withstand repeated flexing, high impact and wear.

Such requirements are all too familiar to developers of footwear applications. In this white paper we feature two very different, but equally innovative, products that demonstrate the design flexibility of Hytrel®.

### Niagara Foot™



The Niagara prosthetic foot in a single Hytrel® molding

The Niagara Foot is an affordable, high-performance prosthetic foot initially designed and intended for active individuals who have been victims of landmines. Its novel, energy-return design relies on the stiff, yet flexible properties of Hytrel® to provide the benefits of stability, effectiveness and comfort. It was developed as part of the Landmine Victims' Relief Program of the Canadian Centre for Mine Action Technology by Niagara Prosthetic & Orthotics International Ltd. (Ontario, Canada) with support from industry partners Hippo Design (Montebello, Québec), Précicad (Québec City, Québec), DuPont (USA & Canada) and a team of engineers from Queen's University (Kingston, Ontario).

The Niagara Foot was designed specifically for individuals with active lifestyles and those who walk on rugged ground. A key aspect of its design lies in its keel – a single, S-shaped part, injection-molded from Hytrel® 8238, which acts like a spring to provide energy storage and return during the gait cycle. “The energy-return principle incorporated into the design of the Niagara Foot allows the user to walk more naturally than conventional designs,” explains Rob Gabourie, founder of Niagara Prosthetic & Orthotics Corporation and inventor of the Niagara Foot. “Patients are able to detect and appreciate the performance of this device, which decreases the muscular effort required for walking.”

The combination of low flex fatigue and high stress resistance provided by Hytrel® was key to achieving this concept – indeed, Rob Gabourie is convinced that his design will not work with any other material. While a number of other materials, including polyoxymethylene

(POM) and polyamides, were unable to pass two million cyclic loads due to deformation or, in some cases, structural failure, Hytrel® clearly exceeded this milestone during the rigorous testing program. “Of particular interest is the ability of Hytrel® to store and release energy,” states Dan Curran-Blaney, Application Development Representative at DuPont Canada.

“ Hytrel® complies with this specific design by mimicking the natural movement of the ankle complex. Yet, beyond this fundamental requirement, the material must be able to endure severe cycling of these loads, as experienced in normal usage. The unique attribute of Hytrel® is its ability to recover its shape, while continuously cycling under load, which enhances its spring-like properties. ”

Dan Curran-Blaney – DuPont Canada

Further clarification for its exceptional performance in such a demanding application is provided by the material's processing behavior, as Helga Plishka, technical representative at DuPont Canada, explains: “The geometry of the current design requires abnormally thick wall sections. Because Hytrel® flows easily to produce a well-packed part, the occurrence of the voids, which were prevalent in parts molded with POM or polyamide, was eliminated – essential for achieving flex fatigue resistance.”



## Walking on Hytrel®

### Fimbulvtr Snowshoe

Fimbulvtr might not be a household name but with three major awards under its belt – the ISPO Brand New, Red Dot Award and The Norwegian Design Councils Award for Design Excellence – it is becoming one of the foremost players in the snowshoe world. Fimbulvtr, which means Great Winter in old Norse, are themselves based in Norway – a country where it truly pays to understand the qualities required for a great snowshoe.

Fimbulvtr have developed a highly durable, light weight snowshoe, with an innovative Hytrel® feature the heart of the product. This molding, containing Fimbulvtr's patented All Direction Hinge, distributes weight in all directions so the wearer can stroll over steep, off-angled terrain with ease.

Hytrel® thermoplastic elastomer is used for this hinge because it has extreme fatigue endurance combined with stability of performance between 23°C and -30°C, in both stiffness and toughness. In fact, it's so strong that Fimbulvtr offer a lifetime warranty on their snowshoes.

Injection molding allows the snowshoe base to be produced in one single part maximizing material usage and preventing future breakage.

The honeycomb pattern of the shoe was born from the inspiration of nature in its strongest form and gives the shoe maximum strength and low density.

“ We tried to take away as many elements as possible leaving you only with what's best to carry you over snow. It is all about stripping it down and making the best kind of snowshoe. ”

Fredrik Wenstøp – Designer, Fimbulvtr



### Why did both designs use Hytrel®?

In both applications the main reason for specifying Hytrel® was the fact it can be repeatedly flexed without cracking or breaking, as shown through testing where it performs very favorably versus thermoset rubbers and virtually any other thermoplastic elastomer.

Combined with the fatigue endurance of Hytrel® is a relatively stable stiffness over a wide temperature range, which gives a more consistent feel particularly at low temperatures, where other plastics would become noticeably stiffer.

In addition to these performance benefits, Hytrel® is an excellent choice for innovative designs requiring more complex molding geometries.

Due to its flow characteristics Hytrel® can be molded with a range of thicknesses that create a unique combination of variable stiffness and flexibility. This allows for the design of components with integrated features, reducing the number of parts in an assembly and thus saving on costs. This is demonstrated perfectly by the Niagara prosthetic foot.

**For all these reasons, when it comes to designing hard-wearing footwear, you can go further when walking on DuPont™ Hytrel®.**

## Hytrel® in Furniture

### Chair Components

When designers and engineers set out to create innovative new furniture that is more flexible, more durable, lighter and ergonomic; it is often the case that Hytrel® features heavily, as a number of classic designs clearly demonstrate.

#### Generation by Knoll®

Designed by Formway Design of New Zealand, the Generation by Knoll work chair offers a new level of comfort and unrestrained movement, supporting a wide range of postures and work styles typical of today's dynamic workplace. The Generation chair expands the concept of elastic design to a new level, where a chair design can adapt in response to the user's seated posture and working preferences.

#### Material Flexibility and Durability

Key to the Generation chair's flexing and supportive features is the use of the DuPont high performance thermoplastics Hytrel® and Crastin® PBT for key components of its design, the Flex Back and the Dynamic Suspension control. The frameless Flex Back design flexes as the user moves, with the Flex Back Net cradling the user's back and the unique figure-eight structure enabling multi-dimensional movement.



“ The Flex Back Net is fused to the figure-eight structure, yet to identify one component as the skin and the other as the skeleton would be misleading as they are both inextricably intertwined. ”

Benjamin Pardo, Knoll Design Director.

The chair's streamlined and innovative Dynamic Suspension Control, which also uses DuPont™ Hytrel® and Crastin®, is a simple, non-mechanical control that provides a weight-compensated smooth ride. Without the complexity of metal links or springs, the control uses one-third the number of parts of a traditional chair mechanism. The inherent properties of the material's flexibility and durability enable a range of energizing, multi-directional movements.

“The materials give the Flex Back Net and the Dynamic Suspension Control their elasticity and durability, so they essentially provide form and function in one,” describes Pardo. With the materials providing both movement and structure, fewer parts and less energy are required to make the chair. As a result, at 16.8 kg (37 lbs), Generation is lighter than most high performance task chairs.

In the Generation chair, Hytrel® was injection molded into an open structure increasing comfort through superior airflow. Other office chairs achieve airflow and flexibility with a woven mesh of Hytrel® filaments combined with Hytrel® or other polymers to create a mesh chair back or a suspension fabric.



A suspension fabric underneath a foam cushion can be used to eliminate metal springs and other parts without sacrificing comfort. Fewer parts, lower costs and lighter system weight are all key benefits for furniture, automotive and aircraft markets.

Generation by Knoll® is a registered trademark of Knoll®, Inc.



## Hytrel® in Furniture

### Bed Bases

It's not only chairs that take advantage of the performance of Hytrel®, it also plays an increasingly important role in bed design, providing the user with comfortable support for a good night's sleep.

Hytrel® can be used in the flexible joints of slatted wooden bed bases or in highly flexible individual spring elements.

For slatted base construction, Hytrel® is used to provide a spring loaded, non slip fixing between the bed frame and wooden slat. In some designs, with multiple slats on top of each other, a Hytrel® tie can also be used to adjust the stiffness of the support by sliding it along the slat.

When used as a spring, Hytrel® provides independent suspension, superior to any traditional mattress/box-spring combination. The flexible surface of Hytrel® bed springs, in combination with a good quality foam mattress, helps prevent uncomfortable pressure points.

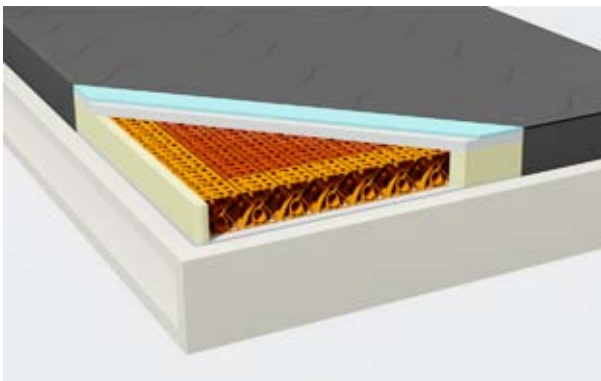

All this can be achieved by utilizing the properties of Hytrel® and selecting the optimum grade based on the application requirements. The range of hardnesses available, from 30 Shore D with a flexural modulus of 150MPa, to 82 Shore D with a flexural modulus of 2600MPa, mean parts can be designed with the bounce of a rubber and the resistance of a rigid plastic.

### Why Use Hytrel® for furniture applications?

In all of these applications the key benefit Hytrel® delivers is its ability to offer consistent flexural and structural properties when bent repeatedly over long periods, more than rubber or virtually any other thermoplastic elastomer. It also has relatively stable stiffness over a wide temperature range, which gives a more consistent feel.

Hytrel® is an excellent choice when innovative designs require the creation of unique parts with multiple performance characteristics because it can be efficiently molded with a range of thicknesses, making it easier to combine different functions into one single component.

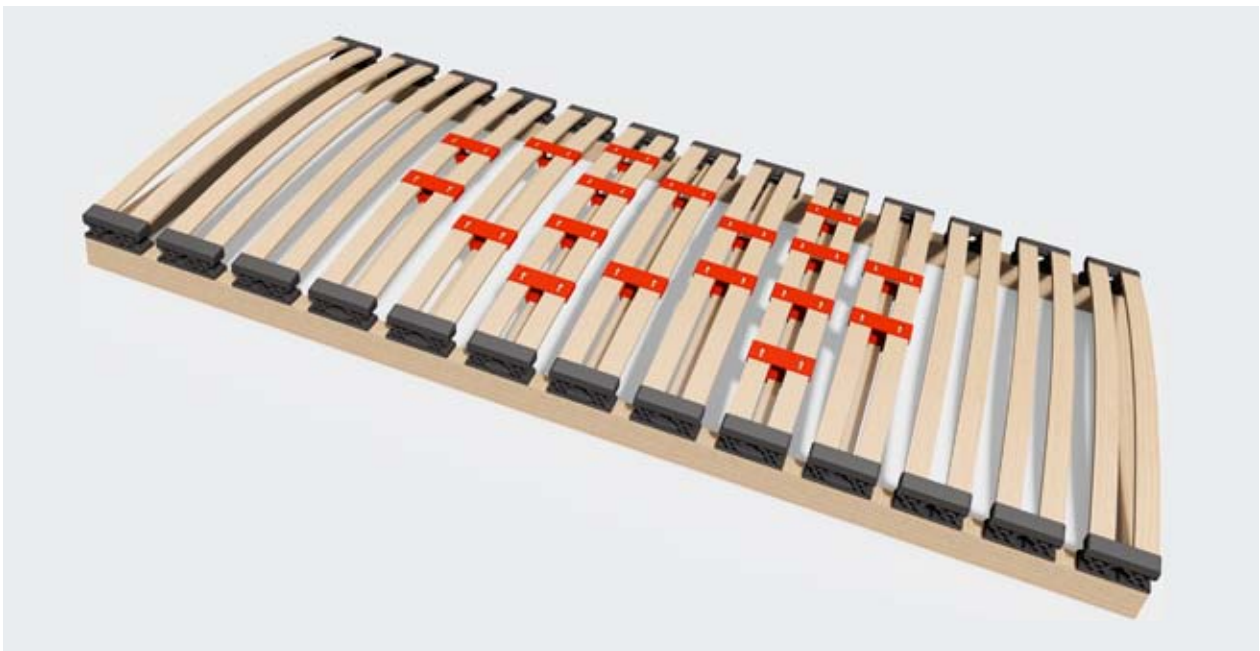

## Wearable Hytrel®

**Wearable Technology – a category with rapid growth**



Sometimes it seems that wearable technology is only just catching up with the hype. Fitness trackers and smart watches have now become mainstream. 2016 was predicted to be the year of virtual reality, and that may have been true with the latest affordable devices entering the market – but what else is coming and where is the sector heading?

The prediction for wearable electronics is still one of rapid growth with increasing awareness of fitness and personal health driving the trend and more smart clothing and devices offered to discretely monitor the body. DuPont Performance Materials is developing polymer technology specifically for wristbands, virtual reality, smart clothing and medical devices. Here we talk about these applications in more detail.

### Wristbands

This segment includes both smart watches and fitness trackers. The overall look and feel for these applications is vitally important so in both cases the outside material needs to have a feel of quality and comfort.

In this category Hytrel® competes with TPU and Silicon rubber, where it offers significant advantages in chemical resistance and less dirt pick up through everyday wear. The compromise with Hytrel® was that its lowest hardness (30 Shore D) was often perceived as being slightly too stiff. In response,

DuPont has developed softer Hytrel® grades in the 70-75 Shore A range, which also provide superior abrasion resistance versus standard soft Hytrel.

These grades have similar hardness but different densities to meet the tactile requirement for a quality watch strap (higher density) versus a mobile fitness band (lower density).



One other key advantage of Hytrel® is that it delivers excellent surface reproduction of etched molding tool textures which has a major influence on the feel of a soft surface. The new softer Hytrel® also offers excellent two component molding adhesion to stiffer grades of Hytrel® and also to amorphous materials such as PC or ABS. This allows designers to integrate regions of different stiffness into the final design.



## Wearable Hytrel®

### Virtual Reality Headsets

Soft touch is a key requirement for the face contact seal of virtual reality headsets. A further development is to make these materials thermally conductive, thus increasing comfort if the headset is worn for an extended period by regulating temperature. Other materials being specified in VR headsets are Delrin® for smooth low friction movement in zooming mechanisms and Sorona® for high gloss scratch resistant housings.

### Making Smart Clothing Easier to Design, Manufacture, Wash and Wear

Embedding electronics more seamlessly into clothing is a clear desire from the market so that the sensors do not detract from the style of a garment, while continuing to carry out analysis of the body for functions including heart rate, body temperature, sleep tracking and posture. DuPont offers the combined solution of flexible film materials and a complete suite of functional, stretchable electronic ink materials for smart clothing and other wearable electronics.

DuPont flexible film materials offer the key mechanical properties of flex, stretch and recovery in a thinner film to provide more comfort. DuPont stretchable electronic inks offer an elegant, manufacturing-ready alternative to previous methods of embedding electronics in clothing.

The result is a thin, form-fitting circuit that can be seamlessly fused with standard fabrics, allowing for unprecedented comfort and freedom in wearable electronics design. Smart clothing enabled by DuPont inks is washable and durable – and can withstand up to 100 wash cycles.

A clear customer benefit of working with DuPont is that the respective R&D groups for our Inks and polymers are able to closely collaborate and share information to fine tune the solvents in the ink with the surface properties of the polymer to achieve superior adhesion and conductivity.

The very same technology can also be applied to other electronic components, such as keypads, touch switches and smart medical devices.

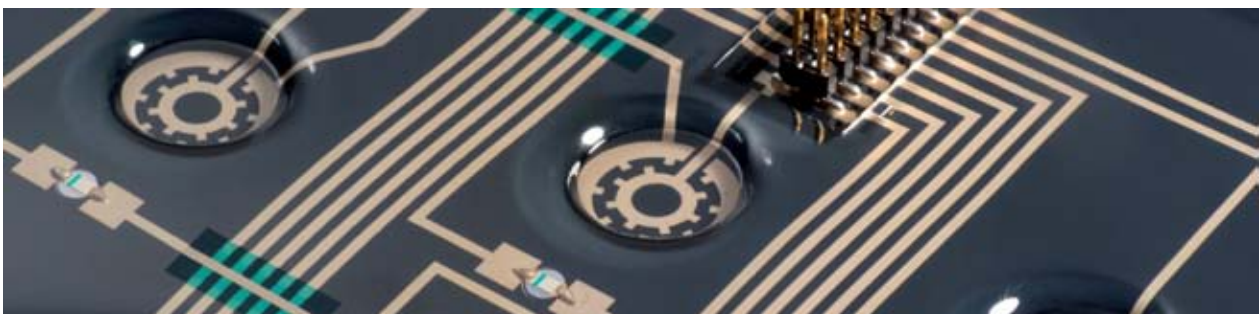
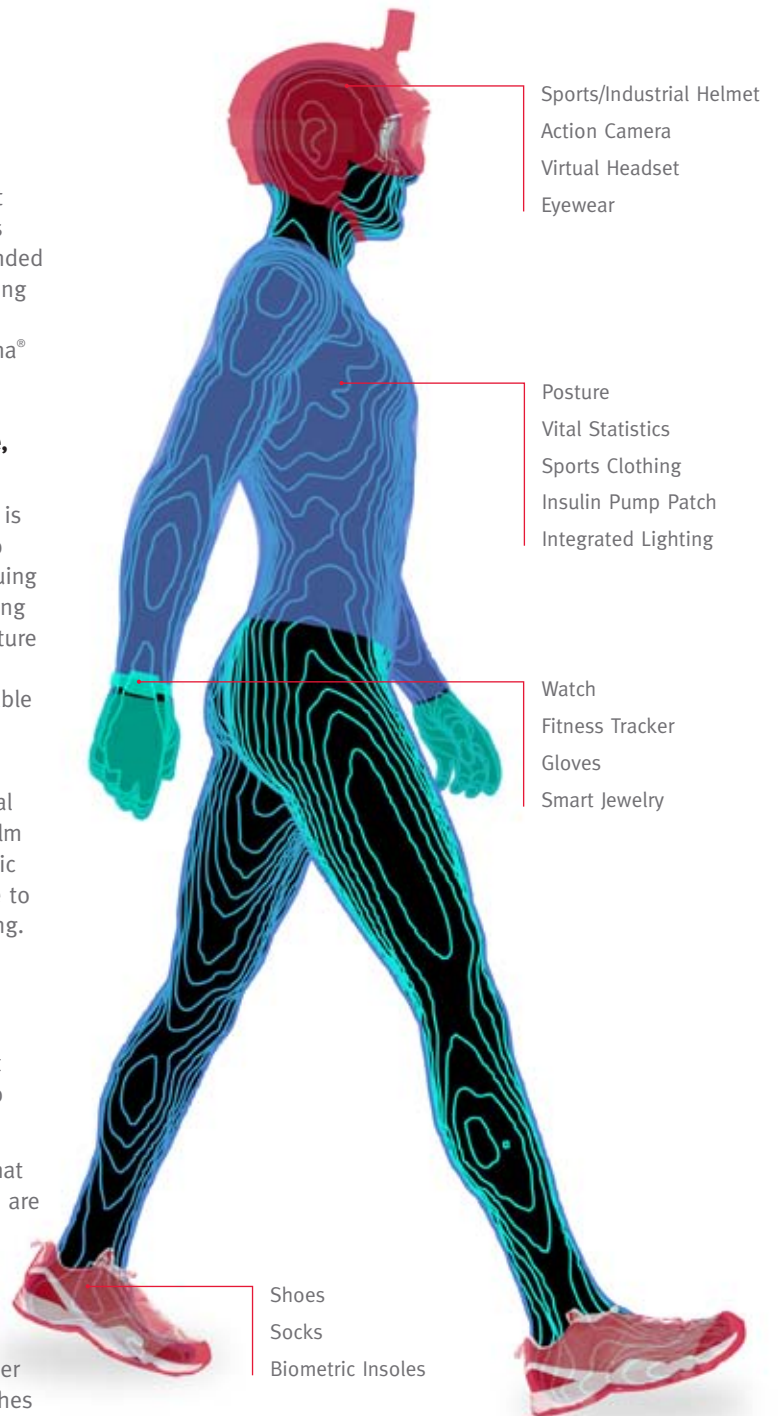

## Design Tips – Snap Fits

Snap-fit assembly of injection molded components is a simple and highly effective technique that has been used for many years. That said, it is always timely to revisit the details because good snap fit design can contribute significantly to cost saving in both assembly and disassembly.

Disassembly in particular is becoming a more important design consideration as brand owners become part of the circular economy, taking back products and recycling valuable materials.

On the flip side, there is nothing more annoying than a snap fit that breaks making a product useless, as commonly occurs on battery covers in toys if the snap fit length is too short for the elongation-to-break of the material.

### Design of Snap Fits

The two main types of snap fit are cantilever and annular, with examples shown below.

The most common type is the cantilever snap fit, so let's look at the design of this first.

The key considerations are

- Deflection required to operate versus the length and material selected
- Radius at the root of the snap fit
- Straight or taper along the length
- Potential to over strain through abuse or unlatching
- Tooling considerations

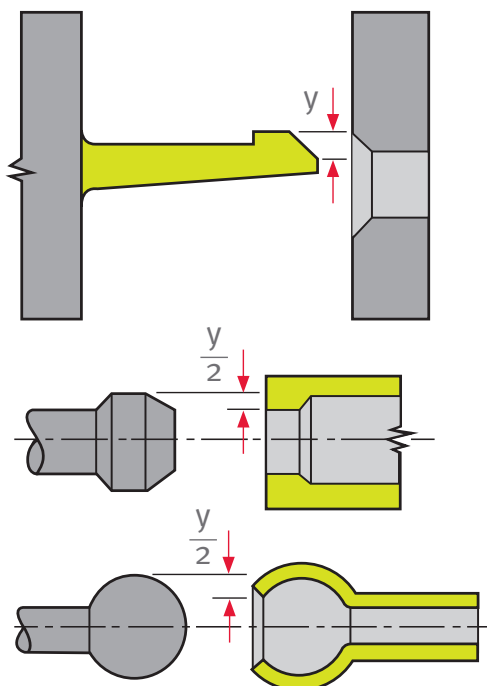

### Allowable Deflection

With a cantilever snap fit, the leg must be able to deflect the distance of the undercut (distance  $y$ ) without overstressing the material. A chart of allowable strain in DuPont polymers typically used for snap fits is shown below. Note the difference of allowable strain in a nylon material if the snap fit is going to be assembled straight after molding or after it has had time to pick up moisture.

Material	Allowable strain	
	Used once (new material)	Used frequently
Delrin® 100	8	2-4
Delrin® 500	6	2-3
Zytel® 101, dry	4	2
Zytel® 101, 50% RH	6	3
Zytel® GR, dry	0.8-1.2	0.5-0.7
Zytel® GR, 50% RH	1.5-2.0	1.0
Rynite® PET GR	1.2	0.6
Hytrel®	20	10

Suggested allowable strains (%) for lug type snap-fits

For a more precise snap fit performance it is necessary to understand how a part will be both loaded and unloaded. The graph below shows the cyclic loading of Delrin® 500. Here we see that despite the loading curve being non-linear there is only a small permanent set. This recovery behavior makes Delrin® a particularly suitable material for snap fits.

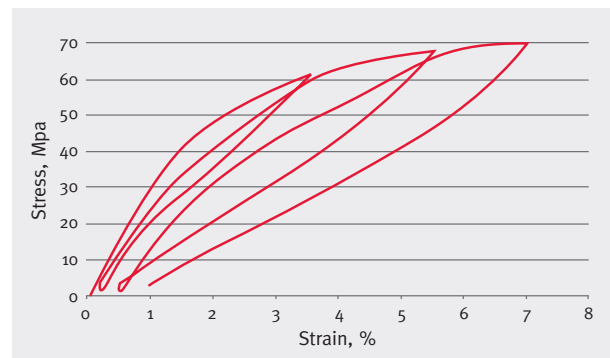

Stress vs. strain plot from cyclic loading at 3 different loading strains

In order to keep below the allowable strain, a key design parameter is the leg length since this value is squared in the allowable deformation calculation. A sufficient radius at its base is important to not cause a large stress concentration. One other suggestion, if tooling allows, is to taper the leg from root to tip as this gives a more even stress distribution and more allowable deflection.

## Design Tips – Snap Fits

For a rectangular section snap fit, a rough calculation of the required length is relatively easy.

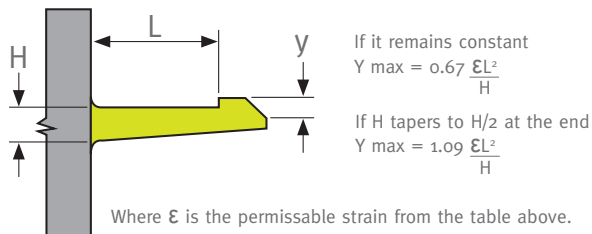

For more complicated geometries such as ring snap fits, additional information is available on the DuPont plastics web site, [www.plastics.dupont.com](http://www.plastics.dupont.com). For even more complicated snap fits, a finite element analysis should be used.

As mentioned earlier, it is essential to put a fillet radius on the end of the snap fit to avoid a stress concentration. A sharp corner could increase the stress in the root by a factor of three and hence reduce the allowable deflection, as shown on the diagram below.

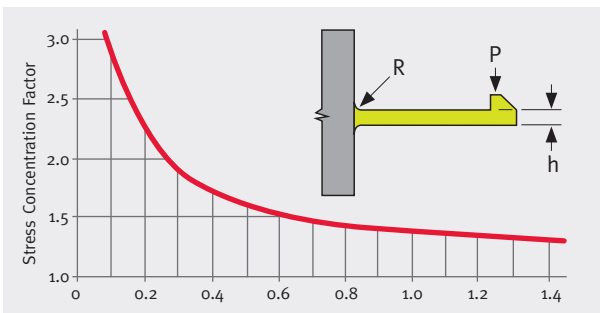

If a snap fit is designed to be reusable, it is important to take into account the possibility of over-stressing during disassembly, particularly if the snap fit is deflected more on release than insertion, as shown below.

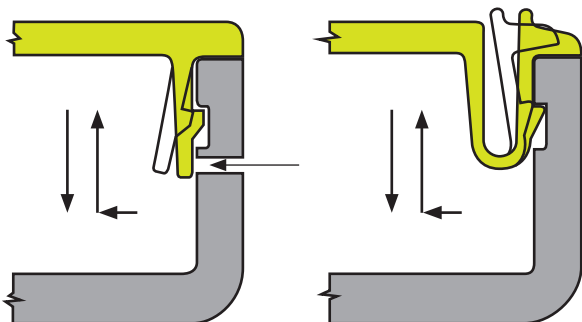

In these cases, the best designs have a physical stop to prevent over-extension. This can be achieved by including a rib behind the snap fit. Often a side action is used in the tool to create the undercut of the snap fit.

However with careful thought this can be avoided. See the principle below.

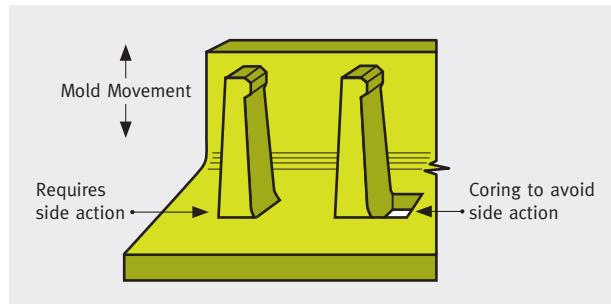

### Annular Snap-fits

An annular snap-fit is essentially an interference ring that radially stretches a mating part until the interference ring reaches an undercut in the mating part. Once assembled, the joint will be very strong and usually stress free. The joint can be either permanent or reversible depending on the return angle.

In an annular snap fit, the material is subjected to high hoop stresses on assembly and so they only work in materials with high strength and elongation such as unfilled Delrin®, Zytel® and Crastin®.

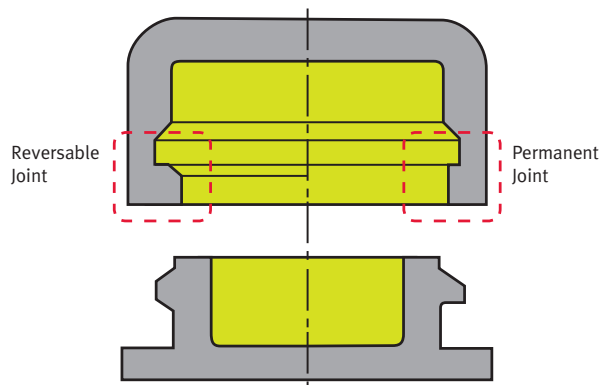

The force required to assemble the snap fit is considerable as the whole diameter of the parts need to be stretched. To achieve this the snap fit should have a maximum lead angle of 45 degrees. The two connecting parts should be designed to seat on each other so that force can be applied at ninety degrees to the interface and the parts deflected evenly.

Another consideration is how to eject the part with the undercut. With a reversible snap fit and good tool opening sequencing it should be possible to bump the part off the tool but with a permanent joint the tool would require a collapsing core.

Further information on the topic of design for assembly can be found on [www.plastics.dupont.com](http://www.plastics.dupont.com) or via your local DuPont representative.

## Design Tips – Seals

Softer materials are commonly used in sealing systems where they can conform under pressure to plug the gap between two parts. As a flexible polymer, Hytrel® is often considered for such applications, but all too often optimum seal performance is not achieved because the designer has attempted to replicate the design details of a rubber seal. Here we look at the key material and design criteria to consider for achieving a successful Hytrel® sealing system.

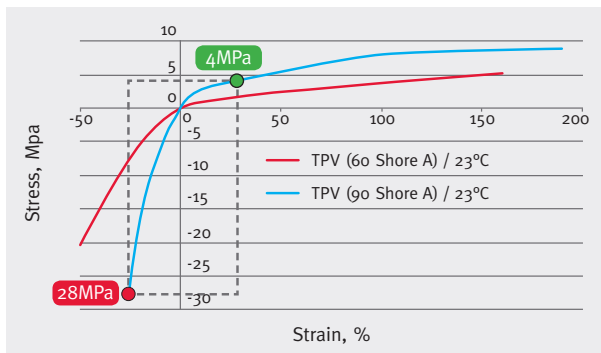

For seals made with Hytrel®, DuPont recommends to avoid designs where the seal is purely compressed as it is with an O-ring seal. The graph below, showing both tension and compression, highlights how the stress rises at a faster rate in compression than in tension and, as we know, higher stress leads to faster onset of creep and set. Of course, it is nearly impossible to design a seal with only pure tensile strain, but working with flexure is a good compromise. In fact, flexural strain is a mix between tensile and compression strain which can easily be achieved by a lip seal design. By designing a seal that is under flexural strain, the stress level is reduced and so is the amount of permanent deformation.

Using a flexure seal design, instead of a purely compression design, will also reduce the compression force of the seal which will also allow material volume reduction and/or offer the possibility to use a stiffer material. This means an O-Ring seal made with rubber could be replaced by a harder Hytrel® with flexure seal design. The compression force of the seal will be nearly the same and maximum strain will be reduced. The use of a stiffer material also opens up the possibility of combining the seal into a housing as one component.

### General Considerations for a Flexure Seal with Hytrel®

- To reduce permanent deformation of a Hytrel® seal, a flexure seal design must be applied
- A thin lip will guarantee minimum strain and therefore minimum permanent deformation to avoid leakage
- To have minimum compression force on a seal, the lip should have an angle of 45° from the vertical

- If the lip seal design has a boss to limit strain, the strain increases with the angle of the lip
- High internal pressure will not cause leakage with the lip seal design as with the compression seal

### Compression Versus Flexure Seal Design

An O-Ring seal design comprises mainly compression strain, with only a small area of tensile strain. The maximum strain is around 60%. A flexure seal design with a lip seal, is a mix of compression and tensile strain which is around 15%. Of course, all these values depend on thickness, design and the deformation height of the seal, but they give an indication to allow a decision on a first design approach.

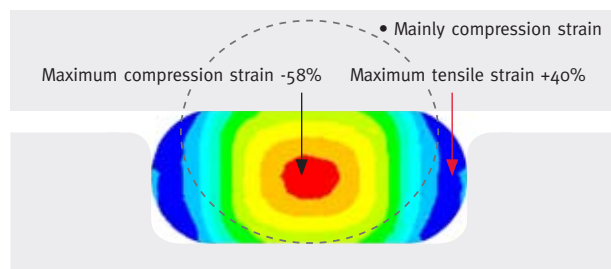

Compression O-Ring Seal Design

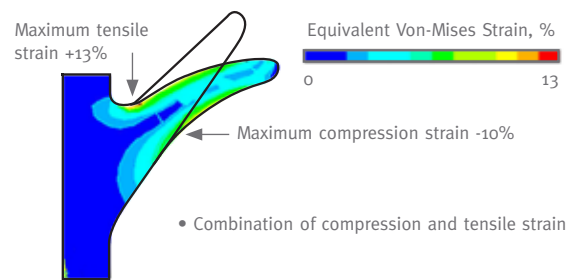

Flexural Lip Seal Design

With a compression seal, a large area of the seal is under maximum strain, but in a lip seal design the strain is concentrated on a small area of the lip. This will help minimize permanent deformation.

### Permanent Deformation

Permanent deformation is a mixture of plastic strain, which is a function of the first strain and creep effect, which in turn is function of strain and time. The creep effect is more prevalent with the increase of stress in the part, as shown below on DuPont™ Hytrel® TPC-ET 5556 @23°C. This graph shows the reduction of stress in the part as a function of the time compared with initial value (Time=1h).

## Design Tips – Seals

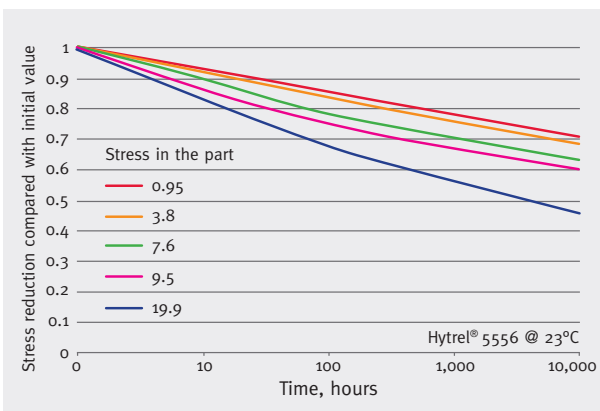
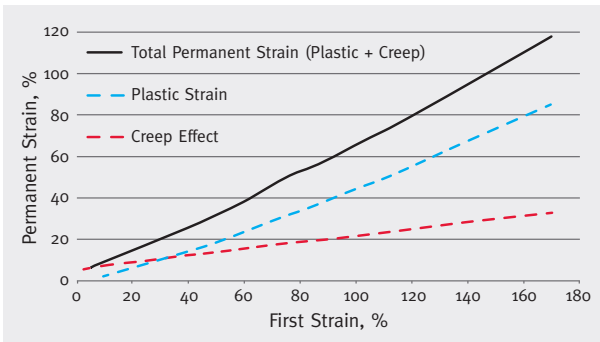

### Strain in a Flexure Seal Design

The maximum strain in a lip seal design is increased with the thickness of the lip. A thinner lip will reduce permanent deformation, but of course the compression force will also be reduced. A vertical embossing can be added to control the maximum seal deformation and therefore reduce plastic strain of the material.

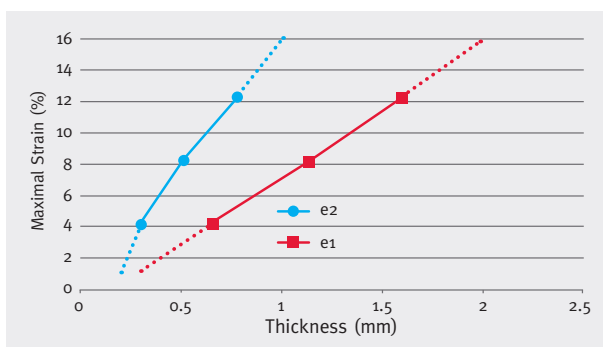
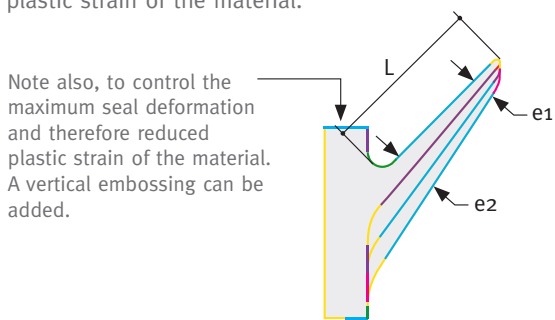

### Lip Seal Design

Compression forces have been calculated for different seal angles. The graph below shows that a mid range seal angle gives the optimum balance of compression force and deflection.

For a near vertical lip of  $10^\circ$  there is a high compression force because more of the lip is under compression.

At  $60^\circ$  the range of usable deflection is low and the compression force increases quickly.

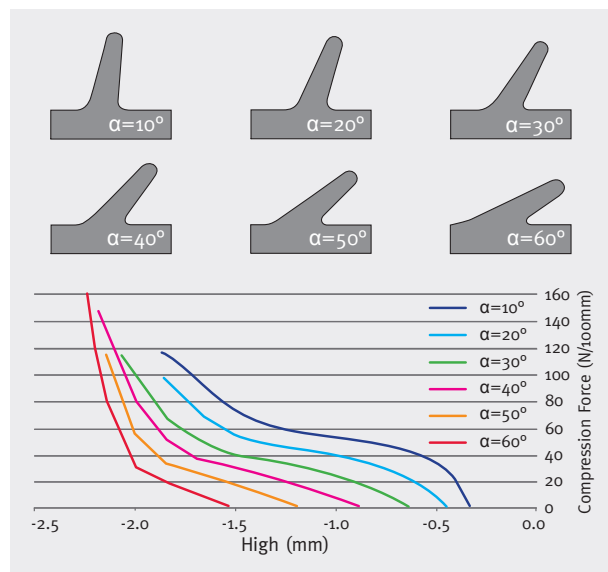

### Pressure Effect

An increase of pressure inside the plastic part will increase contact pressure for the lip seal design, whereas higher internal pressures will reduce contact pressure for a compression seal design, a clear benefit of flexure lip seal systems. This means a large seal compression force is not required to prevent leakage with lip seals designs.

So when it comes to your next sealing challenge, why not consider a Hytrel® lip seal system? We would welcome the opportunity to talk through ideas with you.

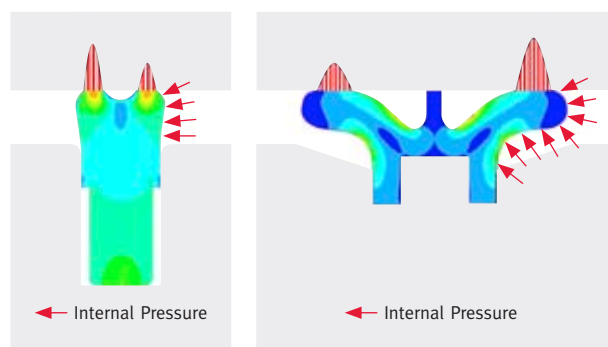

## Hytrel® Applications

### Airbag Systems

DuPont™ Hytrel® thermoplastic elastomer has been used for over 15 years and in millions of vehicles as a deployment cover for airbag systems. A key benefit of Hytrel® is the ability to mold thick and thin regions in the same tool allowing the designer to create a thin seam. When the air bag deploys only this seam tears, so the cover remains in one piece and no flying parts of the air bag door enter the vehicle interior.



### Cable Insulation and Jacketing

Hytrel® is ideal for cable insulation due to its low-temperature flexibility down to -70°C (-158°F) and higher-temperature rating of up to 125°C (257°F) vs. PP, PE, PVC. It's combination of high mechanical and dielectric strength means Hytrel® can be used in thinner layers than many alternative materials, resulting in a substantial reduction in cable diameter, which gives longer flex life at a given bend radius.



### Blow Molded Air Ducts

With 25 years of proven performance Hytrel® is the industry standard, thanks to its excellent balance of grease resistance and high temperature durability. Hytrel® offers the benefits of longer lifetime than rubber, at a thinner wall thickness, with the design freedom for making rigid and flexible sections in a single part.



### Food Contact Materials

A number of Hytrel® grades feature in The DuPont Food Contact Compliant (FG) portfolio of products. Hytrel® combines durability, finish quality and cost efficiency with adherence to food contact standards. As a food contact material, Hytrel® conforms to FDA (Food and Drug Administration) and European Food Contact regulations.



### Gears

Hytrel® provides extra tough teeth for gears subject to extreme shock or when mesh noise reduction is required. Often, just one gear made of Hytrel® is enough to reduce noise in an entire gear train in, for example, a food processor.





## Hytrel® Applications

### Medical Device Materials

DuPont thermoplastic medical device materials, including multiple Hytrel® grades, support design flexibility and help meet regulatory requirements in advanced healthcare applications. This family of Special Control (SC) and Premium Control (PC) grades is backed by testing, regulatory review and DuPont resources who will work with you from your material specification through manufacturing.



### Railway Technology

Various railway applications use Hytrel®, from large buffers and shock absorbers to rail pads. The rail pad is a good example of Hytrel® in action, it's an offset studded pad between the rail and sleeper which bends to absorb vibration of passing train and transmits less force to the concrete sleeper, thus increasing service life.



### Sporting Goods

Hytrel® being a highly impact resistant material family is ideal for sporting goods applications including ski boots, helmets and snowboard components. Hytrel® is selected by ski boot manufacturers due to its strength, durability and high impact resistance, particularly in cold conditions.



### Tubing and Hoses

Hytrel® is used in high performance thermoplastic tubing and elastomeric hoses for a wide range of food, beverage, automotive, oil and gas and industrial applications. It is durable, flexible and resistant to heat and chemicals.



### And many others

The uses for DuPont™ Hytrel® are too numerous to list in full detail. Perhaps you have an exciting new application in mind that is not listed here. If that is the case then please contact us at DuPont Performance Materials to discuss whether Hytrel® is indeed the best choice for your project, or perhaps another advanced polymer from our extensive portfolio of products.









## CONTACT DUPONT

Visit us at [plastics.dupont.com](http://plastics.dupont.com) or [hytrel.dupont.com](http://hytrel.dupont.com)

### Contact DuPont at the following regional locations

#### Europe, Middle East, Africa

+41 22 717 51 11

#### Latin America

+0800 17 17 15

#### Japan

+81 3 5521 8600

#### North America

+1 302 999 4592

#### Greater China

+86 400 8851 888

#### ASEAN

+65 6586 3688

**DuPont Performance Materials (DPM)** is a leading innovator of thermoplastics, elastomers, renewably-sourced polymers, high-performance parts and shapes, as well as resins that act as adhesives, sealants, and modifiers. DPM supports a globally linked network of regional application development experts who work with customers throughout the value chain to develop innovative solutions in automotive, packaging, construction, consumer goods, electrical/electronics and other industries. For additional information about DuPont Performance Materials, please visit [www.plastics.dupont.com](http://www.plastics.dupont.com).

**DuPont** (NYSE: DD) has been bringing world-class science and engineering to the global marketplace in the form of innovative products, materials, and services since 1802. The company believes that by collaborating with customers, governments, NGOs, and thought leaders we can help find solutions to such global challenges as providing enough healthy food for people everywhere, decreasing dependence on fossil fuels, and protecting life and the environment. For additional information about DuPont and its commitment to inclusive innovation, please visit [www.dupont.com](http://www.dupont.com).



<https://www.linkedin.com/company/10609125>



<https://twitter.com/dupontpolymers>



<https://www.youtube.com/user/DuPontPackaging>

#### DISCLAIMER

The information provided in this publication corresponds to DuPont knowledge on the subject at the date of its publication. This information may be subject to revision as new knowledge and experience becomes available. The data provided fall within the normal range of product properties and relate only to the specific material designated; these data may not be valid for such material used in combination with any other materials, additives or pigments or in any process, unless expressly indicated otherwise.

The data provided should not be used to establish specification limits or used alone as the basis of design; they are not intended to substitute for any testing you may need to conduct to determine for yourself the suitability of a specific material for your particular purposes. Since DuPont cannot anticipate all variations in actual end-use and disposal conditions, DuPont does not guarantee results, makes no warranties and assumes no liability in connection with any use of this information. All such information is given and accepted at the buyer's risk. It is intended for use by persons having technical skill, at their own discretion and risk. Nothing in this publication is to be considered as a license to operate under or a recommendation to infringe any patent.

**CAUTION:** Do not use DuPont materials in medical applications involving implantation in the human body or contact with internal body fluids or tissues unless the material has been provided from DuPont under a written contract that is consistent with DuPont policy regarding medical applications and expressly acknowledges the contemplated use. For further information, please contact your DuPont representative. You may also request a copy of DuPont POLICY Regarding Medical Applications H-50103-5 and DuPont CAUTION Regarding Medical Applications H-50102-5.

Copyright © 2017 DuPont. All rights reserved. The DuPont Oval Logo, DuPont™, and all products denoted with ® or ™ are trademarks or registered trademarks of E.I. du Pont de Nemours and Company or its affiliates.

